

O2V104

O2VWRPKG/ON/GM/E1/E2/T

Object recognition

Please note the wiring of the sensor and the sockets (see data sheet) as for 8-pole sockets the core colours are not standardised.

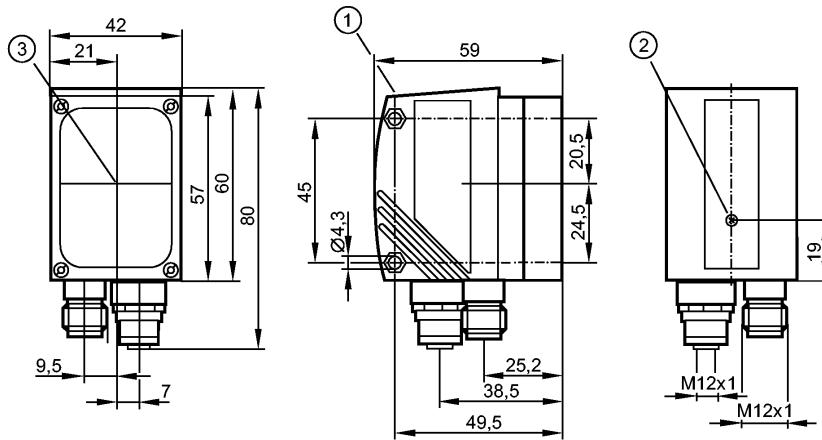

- 1: display
- 2: Focus setting
- 3: Centre of the lens axes

Made in Germany



Product characteristics

Object inspection sensor	
Max. field of view size: 400 x 300 mm	
Illumination: white light	

Electrical data

Operating voltage	[V]	24 DC ± 10 %
Current consumption	[mA]	< 300
Type of light		White light
Protection class		III
Reverse polarity protection		yes
Connection external illumination	[V]	24 V DC
Type of sensor		CMOS image sensor B/W, VGA resolution 640 x 480

Inputs

Circuit	max. 2 (configurable) / 24 V PNP to IEC 61131-2 type 2
Trigger	external; 24 V PNP to IEC61131-2 type 2 internal

Outputs

Output	max. 5 (configurable) / 24 V PNP
Max. current load per output	[mA] 100
Voltage drop	[V] < 2
Short-circuit protection	yes
Overload protection	yes

Range

Operating distance	[mm]	75, 100, 200, 400, 1000, 2000					
Field of view size	[mm]	15 x 11	20 x 15	40 x 30	80 x 60	200 x 150	400 x 300
Resolution	[mm]	0.08	0.12	0.25	0.52	1.25	2.53
Detection rate	[Hz]	≤ 20					
Motion speed	[m/s]	typ. 1					

O2V104

O2VWRPKG/OV/GM/E1/E2/T

Object recognition

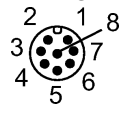
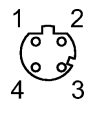
Software / programming	
Parameter setting options	via 2 pushbuttons and 10-segment display or via PC / notebook with operating software
Interfaces	
parameter setting interface	Ethernet TCP/IP; 10Base-T / 100Base-TX
Process interface	Ethernet TCP/IP (Port: 50010), EtherNet/IP
IP address	192 .168 .0 .59
subnet mask	255.255.255.0 (Class C)
gateway IP address	192 .168 .000 .201
MAC address	see type label
Environment	
Ambient temperature [°C]	-10...60
Storage temperature [°C]	-40...85
Protection	IP 67
Tests / approvals	
EMC	radiation of interference to EN 61326 noise immunity to EN 61326
Shock resistance	EN 60947-5-2, 7.4.1 IEC 60068-2-27
Vibration resistance	EN 60947-5-2, 7.4.2 IEC 60028-2-6:
Mechanical data	
Housing materials	housing: diecast zinc powder-coated; window: glass; LED window: polycarbonate
Weight [kg]	0.413
Displays / operating elements	
Display	Function display 3 x LED green 4 x LED yellow Display unit / status 4-digit 10-segment display
Electrical connection	
Connection	M12 plug, 8 poles M12 socket, 4 poles
<p>Wiring</p>  	<p>M12: Process connection</p> <ul style="list-style-type: none"> 1: U+ 2: trigger input 3: 0 V 4: Switching output 5 / trigger output 5: Switching output 3 / Ready 6: Switching output 4 / OUT 7: Switching output 1 / Input 1 8: Switching output 2 / Input 2 <p>Ethernet: parameter setting/process connection</p> <ul style="list-style-type: none"> 1: TD+ 2: RD+ 3: TD- 4: RD-
Accessories	
Accessories (optional)	Operating software; Mounting accessories
Remarks	



O2V104

O2VWRPKG/ON/GM/E1/E2/T

Object recognition

Remarks	cULus - Class 2 source required
---------	---------------------------------

Pack quantity	[piece]	1
---------------	---------	---

ifm electronic gmbh • Friedrichstraße 1 • 45128 Essen — We reserve the right to make technical alterations without prior notice. — GB — O2V104 — 15.12.2010

Please note the wiring of the sensor and the sockets (see data sheet) as for 8-pole sockets the core colours are not standardised.